



Lockhart ES Easements

Facilities Committee Presentation

Jacqueline B. Ellis, Chief of Schools

Betty L. Parker, Senior Director, Real Estate Services

July 14, 2021

Lockhart ES GIS Aerial – GoRaleigh Transit Easement Location

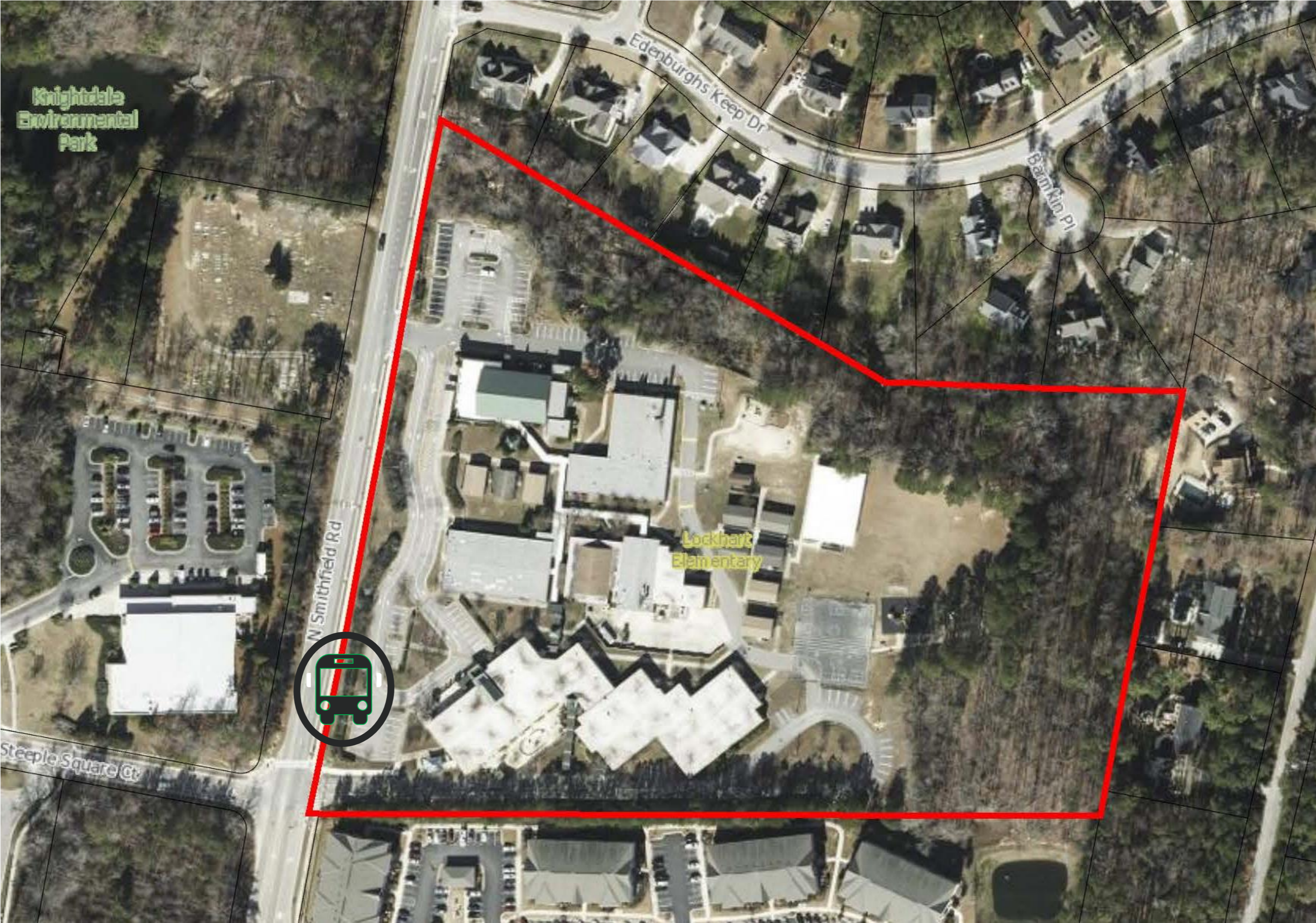

Transit Easement Areas Requested by GoRaleigh

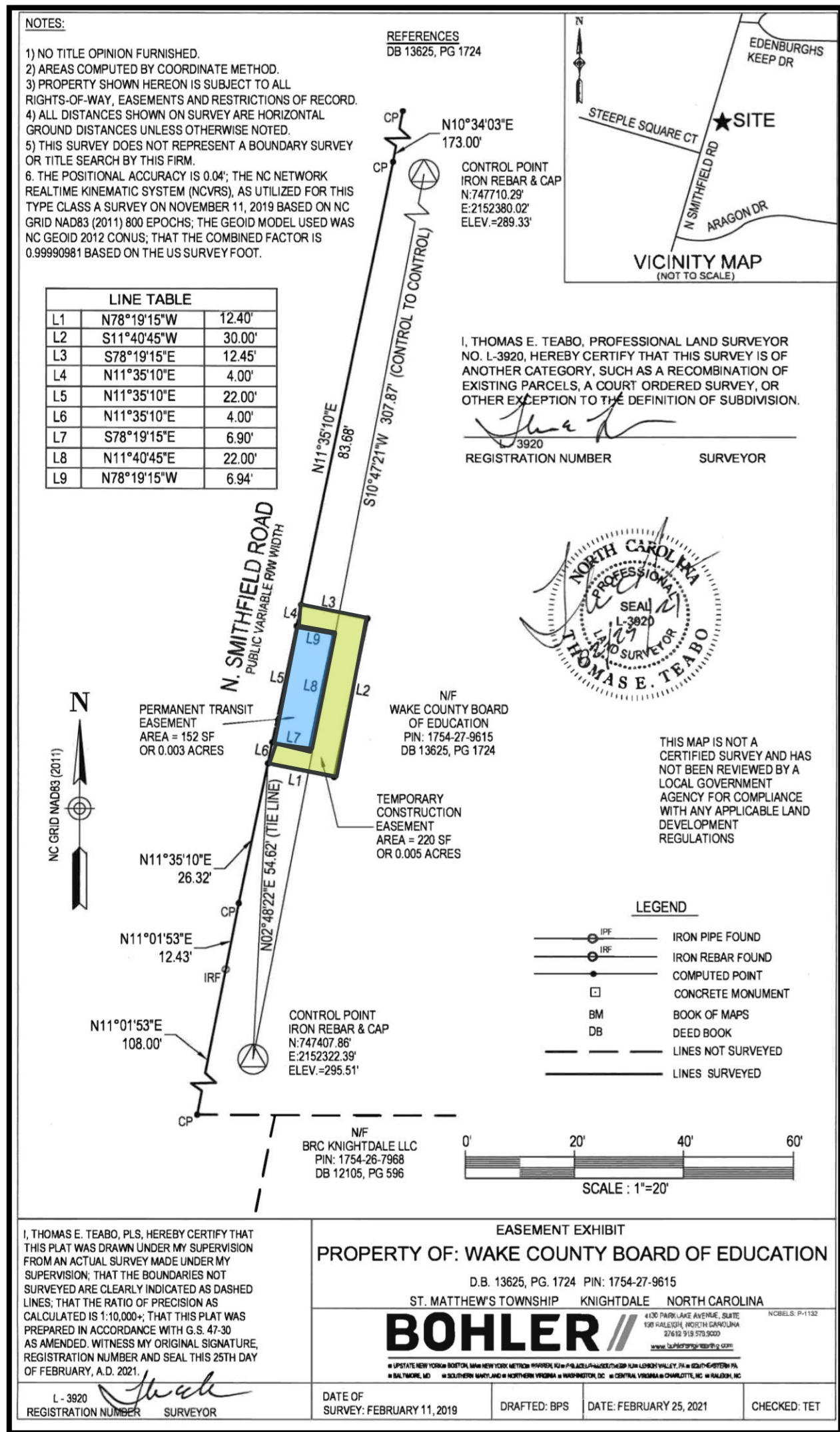

Bus Transit Shelter

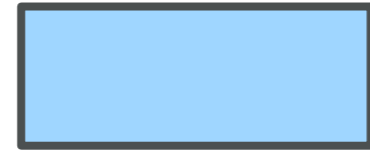

Permanent Transit Easement (152 square feet)



Temporary Construction Easement (220 square feet)

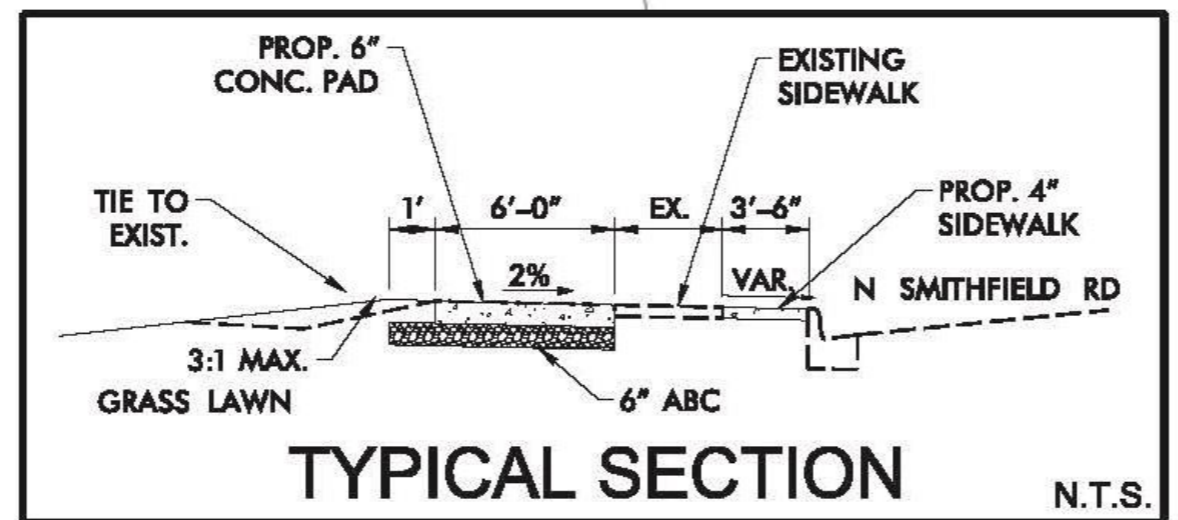

WCPSS Schools with GoRaleigh/GoCary Bus Stops within 0.25 Miles

#	School Name	Grade Level	*Bus Stop #	#	School Name	Grade Level	*Bus Stop #
GoRaleigh							
1	Athens Drive High	High	4	28	Poe Elementary	Elementary	7
2	Broughton High	High	10	29	Powell Elementary	Elementary	2
3	Enloe High	High	2	30	Root Elementary	Elementary	4
4	Mary E. Phillips High School	High	3	31	Southeast Raleigh Elementary	Elementary	2
5	SCORE Academy: Garner	High	5	32	Stough Elementary	Elementary	4
6	Southeast Raleigh High	High	2	33	Underwood Elementary	Elementary	7
7	Wake Early College Of Health And Sciences	High	13	34	Walnut Creek Elementary	Elementary	2
8	Wake Young Men's Leadership Academy	Middle/High	13	35	Washington Elementary	Elementary	2
9	Wake Young Women's Leadership Academy	Middle/High	3	36	Wilburn Elementary	Elementary	2
10	Longview School	Middle/High	4	37	Wiley Elementary	Elementary	6
11	Infinity Program	Middle/High	2	GoCary			
12	Carnage Middle	Middle	6	38	Cary High	High	1
13	Ligon Middle	Middle	14	39	Crossroads FLEX High	High	3
14	Martin Middle	Middle	4	40	SCORE Academy: Cary	High	3
15	Moore Square Middle	Middle	16	41	Apex Middle	Middle	1
16	Oberlin Middle	Middle	8	42	East Cary Middle	Middle	3
17	River Oaks Middle	Middle	1	43	Connections Middle	Middle	5
18	Mount Vernon - Bridges Program	Elementary/Middle	1	44	Adams Elementary	Elementary	2
19	Barwell Elementary	Elementary	2	45	Cary Elementary	Elementary	3
20	Bugg Elementary	Elementary	8	46	Northwoods Elementary	Elementary	3
22	Fuller Elementary	Elementary	2	47	Swift Creek Elementary	Elementary	1
23	Hunter Elementary	Elementary	9	48	Weatherstone Elementary	Elementary	1
24	Joyner Elementary	Elementary	3	49	Crossroads I-III	Admin	2
25	Lacy Elementary	Elementary	3	GoRaleigh Future School Sites			
26	Olds Elementary	Elementary	4	1	Capital Boulevard High Site	High	5
27	Partnership Elementary	Elementary	20	2	M17 Future Poole Road MS Site	Middle	2
				3	E39 Future Poole Road ES Site	Elementary	4

* Bus Stop # is based upon GoRaleigh/GoCary Bus Stop IDs

WCPSS Schools with GoRaleigh/GoCary Bus Stop Access

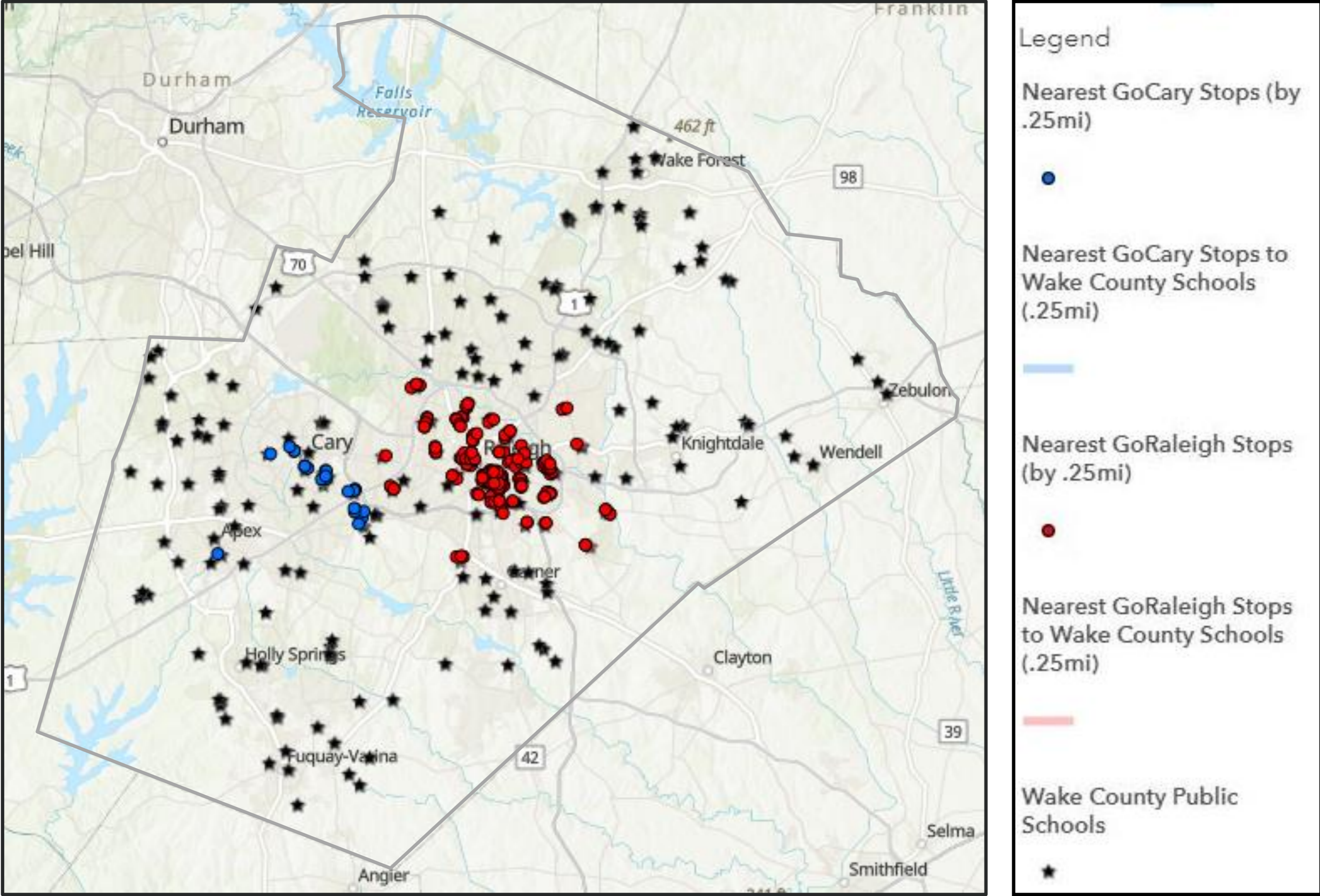

The Wake County Transit Plan Includes Four “**BIG MOVES**”

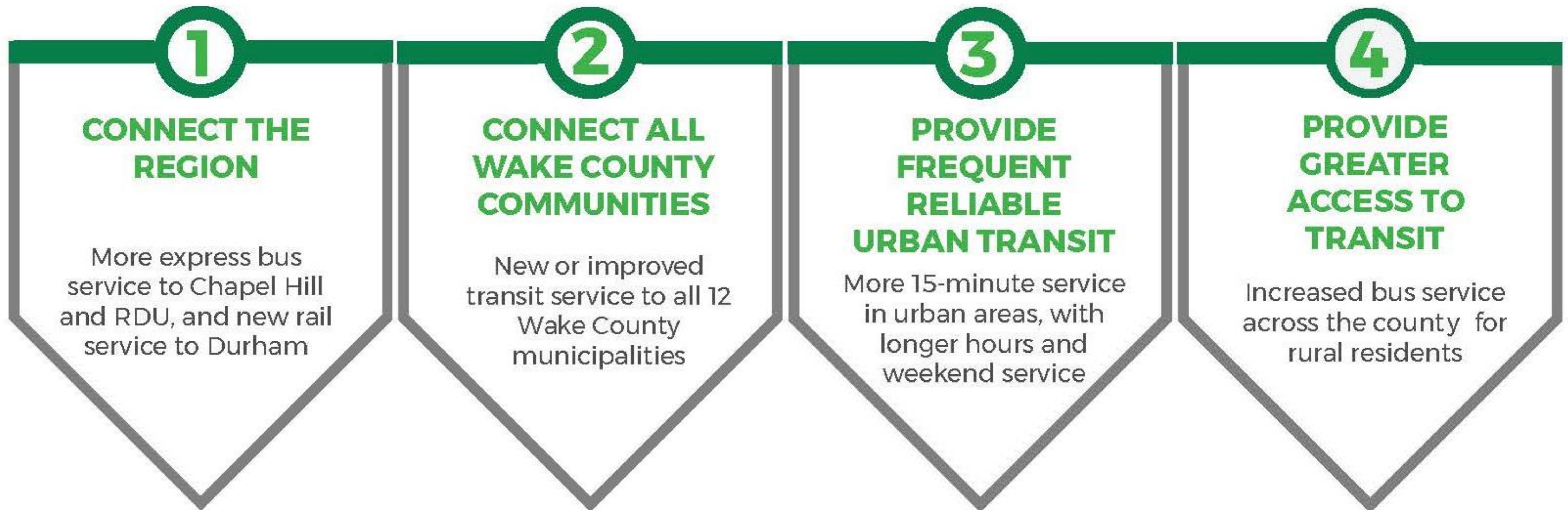

Questions?

